



## KCK118 LED CONVERSION KIT

The King Luminaire KCK118 Washington LED Conversion Kit offers a simple way to convert to high efficiency LED. With tested optical control and dynamic thermal management, King Luminaire's engineered combination of tower heat sinks and vented finial create a complete tested system that requires little maintenance.



## PRODUCT SPECIFICATIONS

### R1/B3 LED ENGINE

Light engine shall be an array of 36, 42, 54 or 63 solid state Cree X-Series high power LEDs (light emitting diodes) mounted to a multi-sided, vertical heat sink of highly conductive aluminum. The LED emitters are mounted to removable circuit boards such that they are in full thermal contact with the vertical heat sink. The vertical heat sink is open at the bottom and vented at the top to provide appropriate dynamic airflow cooling for the LED array. The emitters are arranged in various patterns on each face of the vertical heat sink to provide the required light distribution.

The LED arrays include optical baffles constructed of optical grade ABS plastic with a vacuum metallized reflective surface or clear acrylic precision refractors over each diode. Optical options are designed to efficiently control light distribution in IESNA Type IV & V for the B3 and Type III & V for the R1.

### P4 LED ENGINE

Light engine shall include an array of Cree X-Series high power LEDs (light emitting diodes). The emitters shall be mounted to a metal core circuit board using SMT technology. The LEDs and circuit boards shall then be mounted to a high performance heat sink.

External light control shall consist of high precision refractive lenses mounted above the LED emitter arrays in such a way to achieve optimum upright control. The lenses shall also control horizontal light distribution so that either Type II, III, IV or V IESNA distribution patterns are achieved.

### GLOBE ASSEMBLY

The protective globe shall be molded of either; rippled polycarbonate Miles Makrolon GP/OP Thermoplastic Polymer, or equivalent, or rippled acrylic Acrylite Plus Acrylic Polymer, or equivalent, having a minimum thickness of 0.125".

The globe assembly is a self-contained unit consisting of the globe, rugged cast locking ring, and the LED light engine and optical control. The LED light engine is of a modular design, and is able to be quickly removed from the globe assembly. The globe assembly is secured to the main housing by means of a spring-tensioned, twist-locking Rotolock™ unit to allow tool-less removal of the globe, while maintaining a secure seal between the globe assembly and the main body of the luminaire, making the KCK118 Washington suitable for an outdoor environment.

### DRIVER

The LED universal dimmable driver will be class 2 and capable of 120 - 277V or 347 - 480V input voltage, greater than 0.9 power factor, less than 20% total harmonic distortion. The case temperature of the driver can range from -40°C up to 70°C. Each LED system comes with a standard surge protection designed to withstand up to 20kV/10kA of transient line surge as per IEEE C62.41.2 C High. An

in-line ferrite choke is utilized to provide protection against EFT's. The driver assembly will be mounted on a heavy duty fabricated galvanized steel bracket to allow complete tool-less maintenance.

### PHOTOMETRICS

Fixtures are tested to IESNA LM79 specifications. These reports are available upon request.

### CHROMATICITY

High output LEDs come standard at 3000K & 4000K (+/- 300K) with a minimum nominal 70 CRI. Additional CCT emitters are available upon request.

### LUMEN MAINTENANCE

Reported (TM21) and Calculated (L70) reports are available upon request with a minimum calculated value of 100,000 hrs.

### WIRING

All internal wiring and connections shall be completed so that it will be necessary only to attach the incoming supply connectors to Mate-N-Lok connectors or to a terminal block. Mate-N-Lok shall be certified for 600V operation. Internal wire connectors shall be crimp connector only and rated at 1000V and 150°C. All wiring to be CSA certified and/or UL listed, type SFF-2, SEWF-2, or SEW-2 No. 14 gauge, 150°C, 600V, and color coded for the required voltage.

### THERMALS

Fixtures tested by a DOE sanctioned test facility to determine the maximum in-situ solder-point or junction-point temperatures of the LED emitters. This report is available upon request.

### FINISH

Housing is finished with a 13 step KingCoat™ Super-Durable polyester TGIC powder coat. Standard colors include strobe white, brown metal, marina blue, gate gray, Chicago bronze, standard gold, standard black, federal green and rain forest. Please see our website for a complete list of colors. RAL and custom color matches are available.

### MISCELLANEOUS

All exterior hardware and fasteners, wholly or partly exposed, shall be stainless steel alloy. All internal fasteners are stainless steel or zinc coated steel. All remaining internal hardware is stainless steel, aluminum alloy, or zinc coated steel.

### WARRANTY

The KCK118 Washington LED Conversion Kit comes with a 7 year limited warranty.

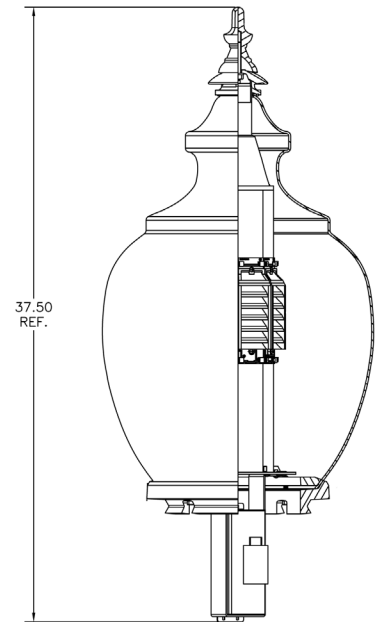

### CERTIFICATION:

CSA US Listed  
Suitable for wet locations  
ISO 9001  
IP66  
ARRA Compliant  
LM79 / LM80 Compliant

### DRIVER INFO:

>0.9 Power Factor  
<20% Total Harmonic Distortion  
120 - 277V & 347 - 480V  
-40°C Min. Case Temperature  
70°C Max. Case Temperature  
Surge Protection: ANSI C136.2 extreme level  
20kV/10kA

### EPA:

1.06 sq. ft.

### FIXTURE WEIGHT:

25 lbs



\*IDA Certification applicable for maximum 3000K CCT.  
Glass lenses do not apply.  
Contact King Luminaire for product specifications  
that are exempt from CSA Certification.  
08-27-2021

# STEP BY STEP CONVERSION

# KCK118 LED CONVERSION KIT



**STEP 1:** DETERMINE THE HID FIXTURE YOU WISH TO CONVERT TO LED



**STEP 2:** REMOVE THE GLOBE FROM THE HID FIXTURE



**STEP 3:** REMOVE THE BALLAST PLATE AND ASSEMBLY FROM THE HID FIXTURE



**STEP 4:** UNPLUG THE HID POWER LEADS FROM THE BALLAST ASSEMBLY



**STEP 5:** CONNECT THE LED POWER LEADS



**STEP 6:** PLACE THE LED CONVERSION KIT GLOBE ON THE CAPITAL AND ROTOLOCK™ IT INTO PLACE OR ENGAGE THE SET SCREWS IF A NON ROTOLOCK™ GLOBE IS PROVIDED

## HOW TO ORDER

